

CONAN ADD ON INJECTION UNITS



Injecting secondary shot material with a compact add-on injection unit allows for maximum manufacturing flexibility and minimizing valuable floor space. Conan injection units offer big shot sizes, turning any molding machine into a 2 material machine.

- LARGE SHOT** Up to 2 pounds (1 kg) shot size
- HORIZONTAL MOUNTING** Compact design to fit between machines
Floor support offers maximum modularity
- VERTICAL MOUNTING** Fixed to the stationary or moving platten
Compact design for overhead crane clearance



| Screw Diameter | mm | X80 | | | X100 | | | | X200 | | |
|------------------|-------|--------|--------|--------|--------|--------|--------|--------|--------|--------|--------|
| | | 34 | 38 | 40 | 45 | 50 | 55 | 60 | 60 | 65 | 70 |
| Injection Volume | cc | 136 | 204 | 226 | 318 | 432 | 570 | 735 | 792 | 995 | 1350 |
| | in3 | 8.3 | 12.5 | 13.8 | 19.4 | 26.4 | 34.8 | 44.9 | 48.3 | 60.7 | 82.5 |
| Max Inj. P | bar | 1600 | 1300 | 1200 | 1800 | 1500 | 1250 | 1050 | 1750 | 1500 | 1300 |
| | psi | 23,000 | 18,500 | 17,500 | 26,000 | 21,500 | 18,000 | 15,000 | 25,000 | 21,500 | 18,500 |
| Screw Stroke | mm | 150 | 180 | 180 | 200 | 220 | 240 | 260 | 280 | 300 | 350 |
| | in | 5.9 | 7.1 | 7.1 | 7.9 | 8.7 | 9.4 | 10.2 | 11.0 | 11.8 | 14.0 |
| Injection Speed | cc/s | 180 | 225 | 250 | 200 | 250 | 300 | 350 | 350 | 420 | 480 |
| | in3/s | 11 | 14 | 15 | 12 | 15 | 18 | 21 | 21 | 25 | 30 |
| Plast Screw | RPM | 200 | 200 | 200 | 200 | 200 | 150 | 150 | 150 | 150 | 150 |
| Screw torque | Nm | 300 | 300 | 300 | 650 | 850 | 1200 | 1400 | 1400 | 1400 | 1400 |
| | ftlb | 28.0 | 28.0 | 38.4 | 38.4 | 51.1 | 51.1 | 51.1 | 51.1 | 51.1 | 51.1 |
| L/D | | 15.0 | 15.0 | 15.0 | 15.0 | 15.0 | 15.0 | 15.0 | 15.0 | 15.0 | 15.0 |

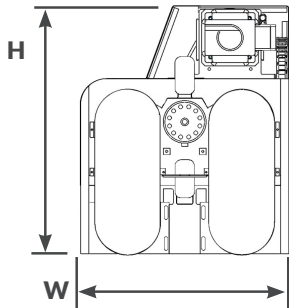
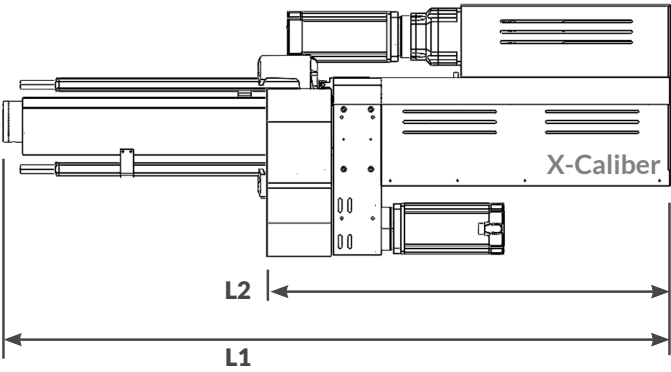
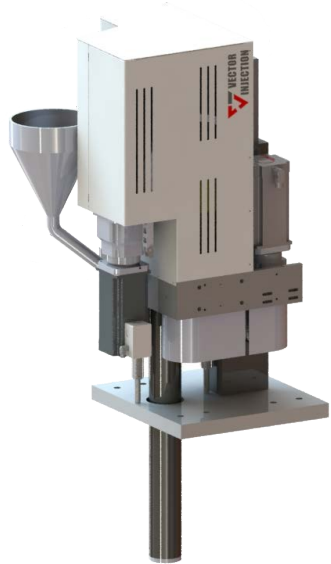

| | L1 | L2 | W | H |
|-------------|------|------|-----|-----|
| X80 | 2400 | 1500 | 500 | 650 |
| X100 | 2500 | 1650 | 550 | 865 |
| X200 | 2575 | 1850 | 805 | 865 |

Dimensions in mm